

# CBCS SCHEME



USN

--	--	--	--	--	--	--	--	--	--

17CV81

## Eighth Semester B.E. Degree Examination, July/August 2021 Quantity Surveying and Contracts Management

Time: 3 hrs.

Max. Marks: 100

*Note: Answer any FIVE full questions.*

1. What is an estimate? Explain briefly purpose and different types of estimate (any three). (20 Marks)
  
2. The details of two room building are shown in the Fig.Q2. Estimate quantities and cost of the following items of work:
  - (i) Earth work excavation for foundation in ordinary soil at Rs.390/m<sup>3</sup>
  - (ii) Bed concrete CC 1:4:8 for foundation at Rs.3600/m<sup>3</sup>
  - (iii) S.S.M for foundation and basement at Rs.2600/m<sup>3</sup>
  - (iv) Burn brick masonry for superstructure in CM 1:6 at Rs.5400/m<sup>3</sup>
  - (v) RCC roof slab M20 at Rs.4800/m<sup>3</sup>

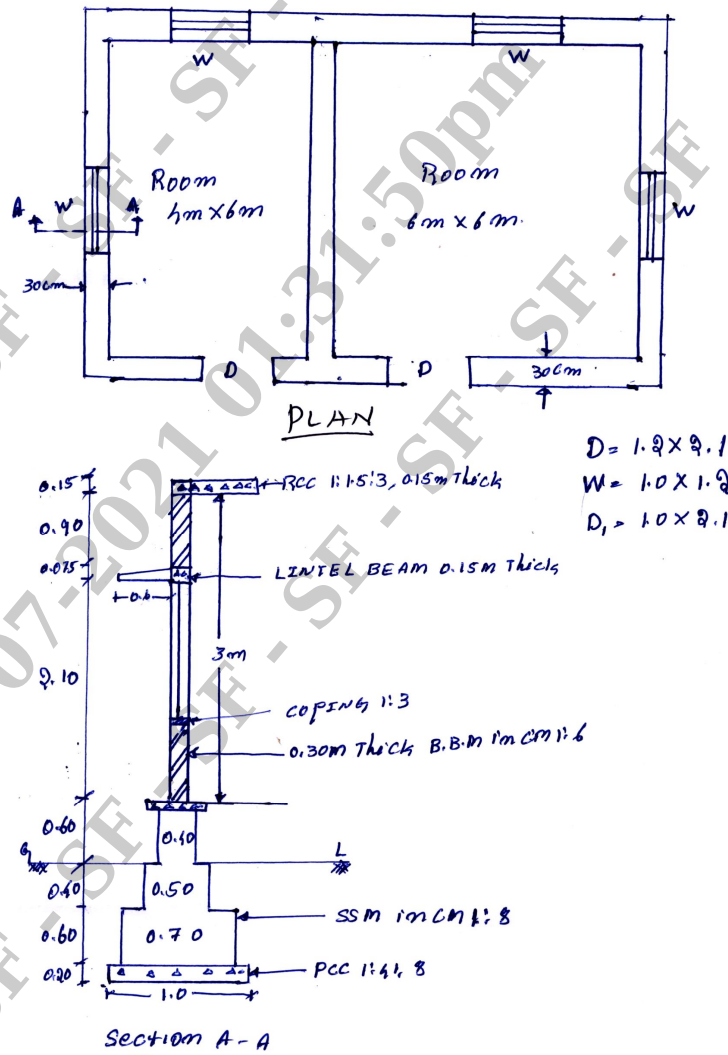

Fig.Q2

(20 Marks)

Important Note : 1. On completing your answers, compulsorily draw diagonal cross lines on the remaining blank pages.  
2. Any revealing of identification, appeal to evaluator and/or equations written eg, 42+8 = 50, will be treated as malpractice.

- 3 The details of septic tank are shown in Fig.Q3. Estimate the quantities of following items and cost.
- (i) Earth work excavation at Rs.440/m<sup>3</sup>
  - (ii) P.C.C. 1:3:6 for bed at Rs.4200/m<sup>3</sup>
  - (iii) B.B.M. in CM 1:4 at Rs.4500/m<sup>3</sup>
  - (iv) Plastering in CM 1:4 at Rs.250/m<sup>2</sup>

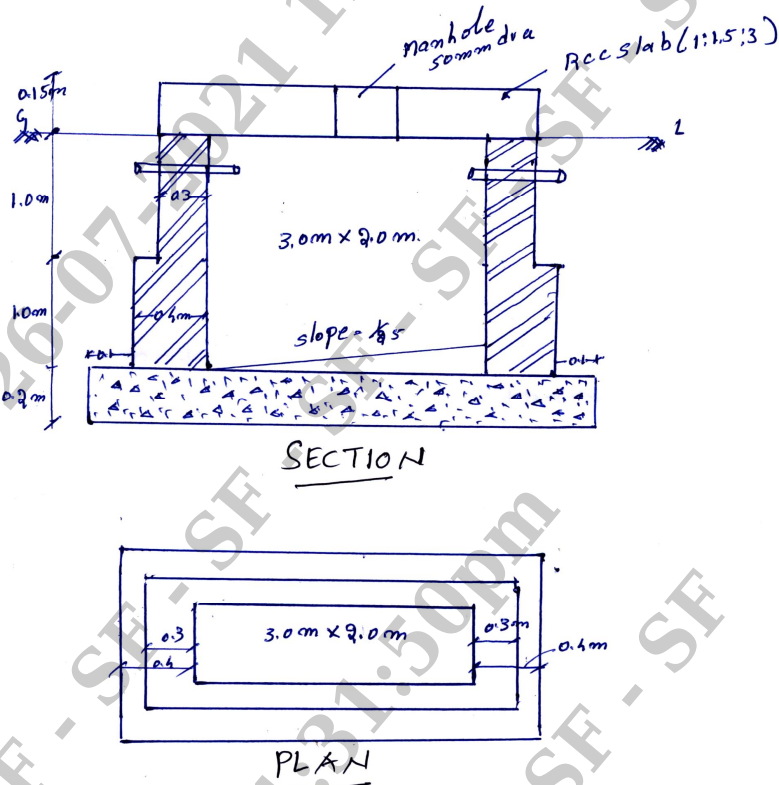

Fig.Q3

(20 Marks)

- 4 Reduced Level (RL) of ground along centre line of a proposed road from chainage 10 to chainage 20 are given below. The formation level at the 10<sup>th</sup> chainage is 107 and the road and the road is in downward gradient of 1 in 150 upto the chainage 14 and the gradient changes to 1 in 100 downward. Formation width is 10 metre and side slope of banking are 2:1 (H:V). Length of chain is 30 m. Estimate the quantities and cost of earth at the rate the cost of filling is 200/m<sup>3</sup> and cutting Rs.140/m<sup>3</sup>.

Chainage	10	11	12	13	14	15	16	17	18	19	20
RL of the ground	105.00	105.60	105.44	105.90	105.42	104.30	105.00	104.10	104.62	104.00	103.3
RL of formation	107.00										
Gradient	Down ward gradient 1 in 150					Down gradient 1 in 100					

(20 Marks)

- 5 Write detailed specification for following:
- (i) Earth work excavation for foundation
  - (ii) Bed concrete for foundation CC 1:4:8
  - (iii) Size stone masonry for foundation in CM 1:8
  - (iv) Burnt brick masonry for super structure in CM 1:6

(20 Marks)

- 6 Analyze rates from first principle for following:  
(i) Random rubble masonry for foundation in CM 1:6  
(ii) Earth work excavation for foundation  
(iii) RCC roof slab CC 1: 1½ : 3 with 1% steel  
(iv) Burnt Brick Masonry (BBM) for super structure in CM 1:6. (20 Marks)
- 7 List the types of contract. Briefly explain any three types of contract. (20 Marks)
- 8 Explain briefly for the following:  
(i) Administrative approval  
(ii) Tender and its process  
(iii) Law of contract as per Indian Contract Act 1872.  
(iv) Prequalification (20 Marks)
- 9 Explain briefly for the following:  
(i) Mobilization and equipment advance  
(ii) Security deposit  
(iii) Breach of contract  
(iv) Suspension of work (20 Marks)
- 10 What is valuation? Explain briefly methods of valuation buildings. (20 Marks)

\* \* \* \* \*